



Thorntons 
The right way to move

9 Church Street

Broughty Ferry, Dundee,
DD5 1EZ



2



3



1

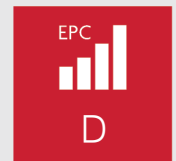

D



Summary

This three-bedroom, traditional end-terrace house in Broughty Ferry offers wonderfully bright and spacious accommodation, as well as providing an excellent opportunity for modernisation, giving the new owner a blank canvas to put their own stamp on. The house lies enviably close to the coast and within easy reach of the other excellent amenities that Broughty Ferry has to offer, such as a wide range of shops, schools at primary and secondary level, transport links, including a train station, sports, leisure, and fitness facilities, and a selection of cafés, restaurants, and bars.

Extras: The property shall be sold as seen.

Features

- Traditional end-terrace house in Broughty Ferry
- Excellent opportunity for modernisation
- Entrance vestibule and hallway
- Airy, east-facing living room
- Garden-facing dining room
- Kitchen and rear vestibule with external access
- Two double bedrooms with built-in storage
- One single bedroom/potential home office
- Four-piece family bathroom
- Large, predominantly lawned shared rear garden
- Access to unrestricted on-street parking
- Gas central heating and double glazing



"This traditional house offers an exciting opportunity to create a modern home with a wealth of original features."







"The home and its location, just a stone's throw from the coast and other amenities, are sure to appeal to a wide demographic."



Floorplan

Ground Floor
Approx. 53.6 sq. metres (576.9 sq. feet)

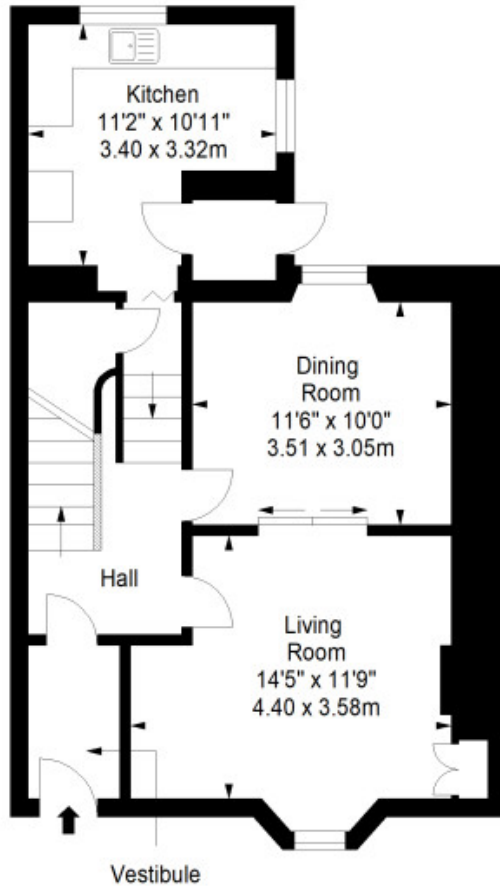

First Floor
Approx. 48.5 sq. metres (522.1 sq. feet)

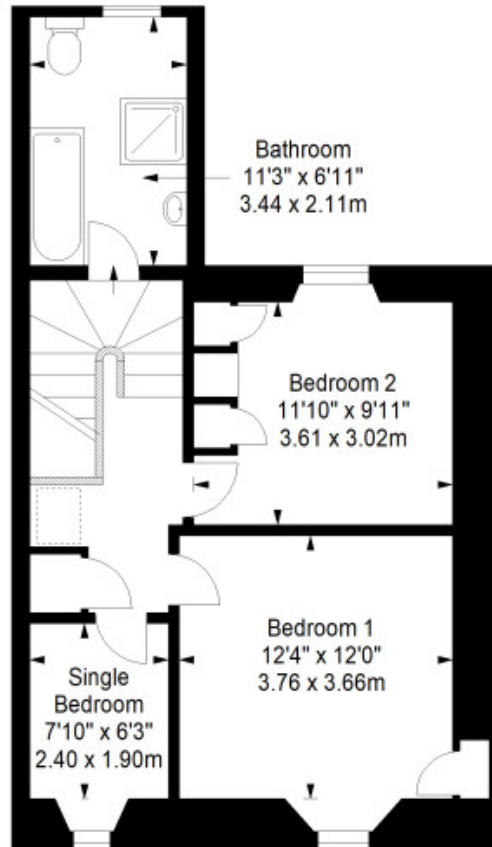

Attic
Approx. 21.7 sq. metres (233.6 sq. feet)

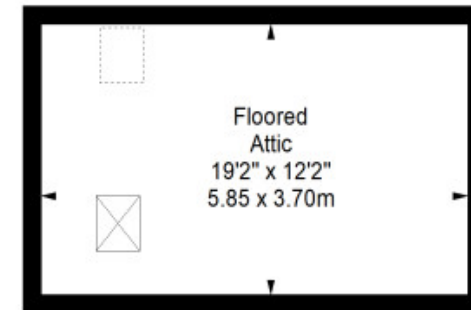

Total area: approx. 123.8 sq. metres (1332.6 sq. feet)



Thorntons

The right way to move

Our Branches

ANSTRUTHER

5A Shore Street, Anstruther, KY10 3EA
01333 310481
anstrutheara@thorntons-law.co.uk

BONNYRIGG

3-7 High Street, Bonnyrigg, EH19 2DA
0131 663 7135
bonnyriggea@thorntons-law.co.uk

DUNDEE

Whitehall House, 33 Yeaman Shore
Dundee DD1 4BJ
01382 200099
dundeeya@thorntons-law.co.uk

FORFAR

53 East High Street, Forfar, DD8 2EL
01307 466886
forfarea@thorntons-law.co.uk

PERTH

7 Whitefriars Crescent, Perth, PH2 0PA
01738 443456
perthea@thorntons-law.co.uk

ARBROATH

165 High Street, Arbroath, DD1 1DR
01241 876633
arbroathea@thorntons-law.co.uk

CUPAR

49 Bonnygate, Cupar, KY15 4BY
01334 656564
cuparea@thorntons-law.co.uk

EDINBURGH

Citypoint, 3rd Floor, 65 Haymarket
Terrace, Edinburgh, EH12 5HD
0131 297 5980
edinburgea@thorntons-law.co.uk

MONTROSE

55 High Street, Montrose, DD10 8LR
01674 673444
montrosea@thorntons-law.co.uk

ST ANDREWS

17-21 Bell Street, St Andrews, KY16 9UR
01334 474200
standrewsea@thorntons-law.co.uk



@ThorntonsPropertyServices



@thorntonsproperty



@ThorntonsPS

Thorntons is a trading name of Thorntons Law LLP
Regulated by The Law Society of Scotland